



Standard Test Methods for Density of Soil and Rock in Place by the Sand Replacement Method in a Test Pit¹

This standard is issued under the fixed designation D 4914; the number immediately following the designation indicates the year of original adoption or, in the case of revision, the year of last revision. A number in parentheses indicates the year of last reapproval. A superscript epsilon (ϵ) indicates an editorial change since the last revision or reapproval.

1. Scope *

1.1 These test methods cover the determination of the in-place density and unit weight of soil and rock using a pouring device and calibrated sand to determine the volume of a test pit. The word “rock” in these test methods is used to imply that the material being tested will typically contain particles larger than 3 in. (75 mm).

1.2 These test methods are best suited for test pits with a volume of from 1 to 6 ft³ (0.03 and 0.17 m³). In general, the materials tested would have a maximum particle size of 3 to 5 in. (75 to 125 mm).

1.2.1 These test methods may be used for larger sized excavations if desirable. However, for larger sized excavations, Test Method D 5030 is preferred.

1.2.2 Test Method D 1556 or D 2167 are usually used to determine the volume of test holes smaller than 1 ft³ (0.03 m³). While the equipment illustrated in these test methods is used for volumes less than 1 ft³ (0.03 m³), the test methods allow larger versions of the equipment to be used when necessary.

1.3 Two test methods are provided as follows:

1.3.1 *Test Method A*—In-Place Density and Unit Weight of Total Material (Section 9).

1.3.2 *Test Method B*—In-Place Density and Unit Weight of Control Fraction (Section 10).

1.4 *Selection of Test Methods:*

1.4.1 Test Method A is used when the in-place unit weight of total material is to be determined. Test Method A can also be used to determine percent compaction or percent relative density when the maximum particle size present in the in-place material being tested does not exceed the maximum particle size allowed in the laboratory compaction test (refer to Test Methods D 698, D 1557, D 4253, and D 4254). For Test Methods D 698 and D 1557 only, the unit weight determined in the laboratory compaction test may be corrected for larger particle sizes in accordance with, and subject to the limitations of Practice D 4718.

1.4.2 Test Method B is used when percent compaction or percent relative density is to be determined and the in-place

material contains particles larger than the maximum particle size allowed in the laboratory compaction test or when Practice D 4718 is not applicable for the laboratory compaction test. Then the material is considered to consist of two fractions, or portions. The material from the in-place unit weight test is physically divided into a control fraction and an oversize fraction based on a designated sieve size. The unit weight of the control fraction is calculated and compared with the unit weight(s) established by the laboratory compaction test(s).

1.4.2.1 Because of possible lower densities created when there is particle interference (see Practice D 4718), the percent compaction of the control fraction should not be assumed to represent the percent compaction of the total material in the field.

1.4.3 Normally, the control fraction is the minus No. 4 sieve size material for cohesive or nonfree draining materials and the minus 3-in. sieve size material for cohesionless, free-draining materials. While other sizes are used for the control fraction ($\frac{3}{8}$, $\frac{3}{4}$ -in.), these test methods have been prepared using only the No. 4 and the 3-in. sieve sizes for clarity.

1.5 Any materials that can be excavated with handtools can be tested provided that the void or pore openings in the mass are small enough (or a liner is used) to prevent the calibrated sand used in the test from entering the natural voids. The material being tested should have sufficient cohesion or particle interlocking to maintain stable sides during excavation of the test pit and through completion of this test. It should also be firm enough not to deform or slough due to the minor pressures exerted in digging the hole and pouring the sand.

1.6 These test methods are generally limited to material in an unsaturated condition and are not recommended for materials that are soft or friable (crumble easily) or in a moisture condition such that water seeps into the hand-excavated hole. The accuracy of the test methods may be affected for materials that deform easily or that may undergo volume change in the excavated hole from standing or walking near the hole during the test.

1.7 The values stated in inch-pound units are to be regarded as the standard. The values given in parentheses are for information only.

1.7.1 In the engineering profession it is customary to use units representing both mass and force interchangeably, unless dynamic calculations ($F = Ma$) are involved. This implicitly

¹ These test methods are under the jurisdiction of ASTM Committee D-18 on Soil and Rock and are the direct responsibility of Subcommittee D18.08 on Special and Construction Control Tests.

Current edition approved Nov. 10, 1999. Published January 2000. Originally published as D 4914 – 89. Last previous edition D 4914 – 89 (1994) ^{ϵ 1}.

*A Summary of Changes section appears at the end of this standard.

combines two separate systems of units, that is, the absolute system and the gravimetric system. It is scientifically undesirable to combine the use of two separate systems within a single standard. These test methods have been written using inch-pound units (gravimetric system) where the pound (lbf) represents a unit of force (weight). However, conversions are given in the SI system. The use of balances or scales recording pounds of mass (lbm), or the recording of density in lbm/ft^3 should not be regarded as nonconformance with these test methods.

1.8 *This standard does not purport to address all of the safety concerns, if any, associated with its use. It is the responsibility of the user of this standard to establish appropriate safety and health practices and determine the applicability of regulatory limitations prior to use.* For specific hazards statements, see Sections 7 and A1.5.

2. Referenced Documents

2.1 ASTM Standards:

- C 127 Test Method for Specific Gravity and Absorption of Coarse Aggregate²
- C 566 Test Method for Total Moisture Content of Aggregate by Drying²
- D 653 Terminology Relating to Soil, Rock, and Contained Fluids³
- D 698 Test Method for Laboratory Compaction Characteristics of Soil Using Standard Effort (12,400 ft·lbf/ft³(600 kN·m/m³))³
- D 1556 Test Method for Density and Unit Weight of Soil in Place by the Sand-Cone Method³
- D 1557 Test Method Laboratory Compaction Characteristics of Soil Using Modified Effort (56,000 ft·lbf/ft³(2,700 kN·m/m³))³
- D 2167 Test Method for Density and Unit Weight of Soil in Place by the Rubber Balloon Method³
- D 2216 Method for Laboratory Determination of Water (Moisture) Content of Soil and Rock³
- D 3740 Practice for Minimum Requirements for Agencies Engaged in the Testing and/or Inspection of Soil and Rock as Used in Engineering Design and Construction³
- D 4253 Test Methods for Maximum Index Density and Unit Weight of Soils Using a Vibratory Table³
- D 4254 Test Method for Minimum Index Density and Unit Weight of Soils and Calculation of Relative Density³
- D 4718 Practice for Correction of Unit Weight and Water Content for Soils Containing Oversize Particles³
- D 4753 Specification for Evaluating, Selecting, and Specifying Balances and Scales for Use in Testing Soil Rock, and Related Construction Materials³
- D 5030 Test Method for Density of Soil and Rock in Place by the Water Replacement Method in a Test Pit⁴
- E 11 Specification for Wire-Cloth Sieves for Testing Purposes⁵

² Annual Book of ASTM Standards, Vol 04.02.

³ Annual Book of ASTM Standards, Vol 04.08.

⁴ Annual Book of ASTM Standards, Vol 04.09.

⁵ Annual Book of ASTM Standards, Vol 14.02.

3. Terminology

3.1 Definitions:

3.1.1 Except as follows in 3.2, all definitions are in accordance with Terminology D 653.

3.2 Definitions of Terms Specific to This Standard:

3.2.1 *control fraction*—the portion of a soil sample consisting of particles smaller than a designated sieve size.

3.2.1.1 *Discussion*—This fraction is used to compare in-place unit weights with unit weights obtained from standard laboratory tests. The control sieve size depends on the laboratory test used.

3.2.2 *oversize particles*—the portion of a soil sample consisting of the particles larger than a designated sieve size.

4. Summary of Test Method

4.1 The ground surface at the test location is prepared and a template (metal frame) is placed and fixed into position. The volume of the space between the top of the template and the ground surface is determined by filling the space with calibrated sand using a pouring device. The mass of the sand required to fill the template in place is determined and the sand removed. Material from within the boundaries of the template is excavated forming a pit. Calibrated sand is then poured into the pit and template; the mass of sand within the pit and the volume of the hole are determined. The wet density of the in-place material is calculated from the mass of material removed and the measured volume of the test pit. The moisture content is determined and the dry unit weight of the in-place material is calculated.

4.2 The unit weight of a control fraction of the material can be determined by subtracting the mass and volume of any oversize particles from the initial values and recalculating the unit weight.

5. Significance and Use

5.1 These test methods are used to determine the in-place unit weight of compacted materials in construction of earth embankments, road fills, and structure backfill. For construction control, these test methods are often used as the bases for acceptance of material compacted to a specified unit weight or to a percentage of a maximum unit weight determined by a standard laboratory test method (such as determined from Test Method D 698 or D 1557), subject to the limitations discussed in 1.4.

5.2 These test methods can be used to determine the in-place unit weight of natural soil deposits, aggregates, soil mixtures, or other similar material.

NOTE 1—The quality of the result produced by this standard is dependent on the competence of the personnel performing it and the suitability of the equipment and facilities used. Agencies that meet the criteria of Practice D 3740 are generally considered capable of competent and objective testing/sampling/inspection. Users of these test methods are cautioned that compliance with Practice D 3740 does not in itself ensure reliable results. Reliable results depends on many factors; Practice D 3740 provides a means of evaluating some of those factors.

6. Apparatus

6.1 *Balance or Scale*—A balance (or scale) to determine the mass of the calibrated sand and the excavated soil having a

minimum capacity of 50 lbm (20 kg) and meeting the requirements of Specification D 4753 for a balance of 0.01-lbm (1-g) readability.

6.2 *Balance or Scale*—A balance (or scale) to determine moisture content of minus No. 4 material having a minimum capacity of 1000 g and meeting the requirements of Specification D 4753 for a balance of 0.1 g readability.

6.3 *Drying Oven*—An oven, thermostatically controlled, preferably of the forced-draft type, and capable of maintaining a uniform temperature of $110 \pm 5^\circ\text{C}$ throughout the drying chamber.

6.4 *Sieves*—No. 4 (4.75-mm) sieve and 3-in. (75-mm) sieve, conforming to the requirements of Specification E 11.

6.5 *Metal Template*—A square or circular template to serve as a pattern for the excavation. Template dimensions, shapes, and material may vary according to the size of the test pit to be excavated. The template shall be rigid enough not to deflect or bend.

NOTE 2—The template shown in Fig. 1 represents a design that has been found suitable for this purpose.

6.6 *Liner*, approximately 1/2-mil thick and large enough to line the test pit with about 1 ft (0.3 m) extending beyond the outside of the template. Any type of material, plastic sheeting, etc., can be used as long as it is flexible enough to conform to the ground surface.

6.7 *Sand Pouring Devices*—(See Fig. 2 for typical devices.) Many types of pouring devices are available. The device must have a spout that will reach into a field test pit so that the drop distance from the end of the spout to the sand surface can be maintained at about 2 in. (50 mm). The inside diameter of the spout must also be large enough to allow free flow of the sand without clogging.

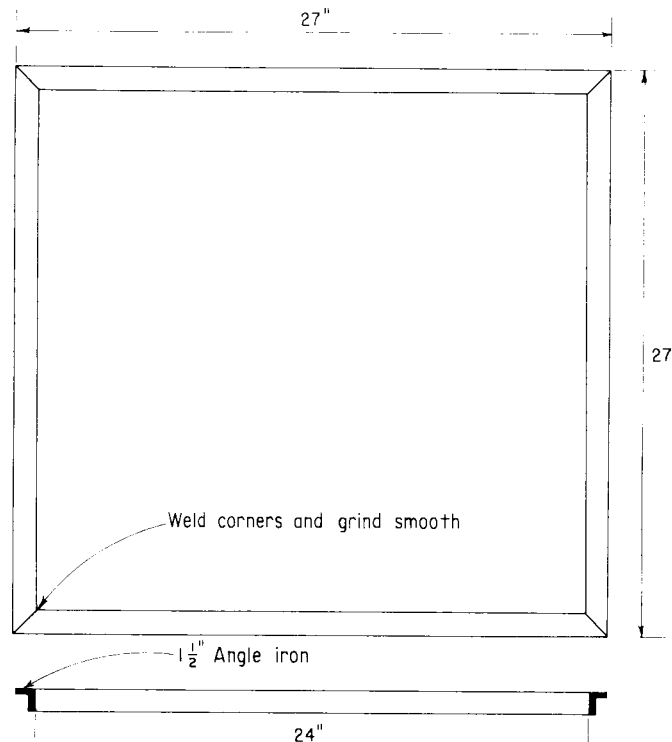

FIG. 1 Typical Metal Template for Excavating Test Pit

6.8 *Metal Straightedge*, about 2 in. (50 mm) high, at least 1/8 in. (3 mm) thick, and with a length 1.5 times the side length (or diameter) of the metal template, used for screeding excess sand placed in template. It must have a thickness or rigidity slweguch that it will not bend when screeding the sand.

6.9 *Sand*—The sand must be clean, dry, uniform, unce-mented, durable, and free flowing. The gradation, physical characteristics, selection, and storage of the sand shall meet the requirements of Test Method D 1556 except that the maximum particle size may be No. 4 (4.75-mm) sieve.

6.9.1 If the test methods are used for test pits larger than about 6 ft³ (0.17 m³), a one-size material relatively free of fines and of a larger particle size, such as pea gravel, may be used.

6.10 *Miscellaneous Equipment*—Shovels for preparing test surface; hammer for seating template; assorted small brushes, picks, chisels, bars, knives, and spoons for digging test pit; buckets with lids, seamless cans with lids, or other suitable containers for retaining the test sample and sand without moisture change; bags or other suitable containers for waste sand; cloth for collecting excess sand or soil; and assorted pans and porcelain dishes suitable for drying moisture content specimens.

7. Hazards

7.1 Precaution:

7.1.1 These test methods may involve handling heavy loads.

7.1.2 Some sands used in the procedures outlined herein may be dusty and appropriate precautions should be taken when mixing and pouring.

7.2 Caution:

7.2.1 Materials that may flow or deform during the test must be identified and appropriate precautions taken.

7.2.2 Movement of heavy equipment in the immediate test area should not be permitted during the volume determination.

7.2.3 Errors may arise in the computed unit weight of material due to the influence of excessive moisture in the soil. These errors may be significant in materials with high permeability, such as sands and gravels, where the bottom of the test hole is close to or below the water table. Errors may also arise due to change in density of the calibrated sand as it becomes wetted from capillary or freestanding water while performing the test. This problem becomes evident when removing the calibrated sand from the test hole and wet sand is observed on the bottom or sides of the test hole. When a liner is used, the buoyant forces of free water beneath or behind the liner may adversely affect the volume determination.

7.2.4 Suitably protect the test area and equipment during periods of inclement weather such as rain, snowfall, or high wind. If the in-place moisture content value is required, it may be necessary to protect the area from direct sunlight.

7.2.5 Numerous containers may be required during performance of these test methods. Properly label all containers to avoid a possible mixup.

7.2.6 The total mass of the calibrated sand, or the soil sample, or both, may exceed the capacity of the scale used, requiring cumulative determinations of mass. Take care to ensure that the total mass is properly determined.

7.2.7 Pouring devices with valves provide consistent sand flow from test to test only if the valve is opened completely

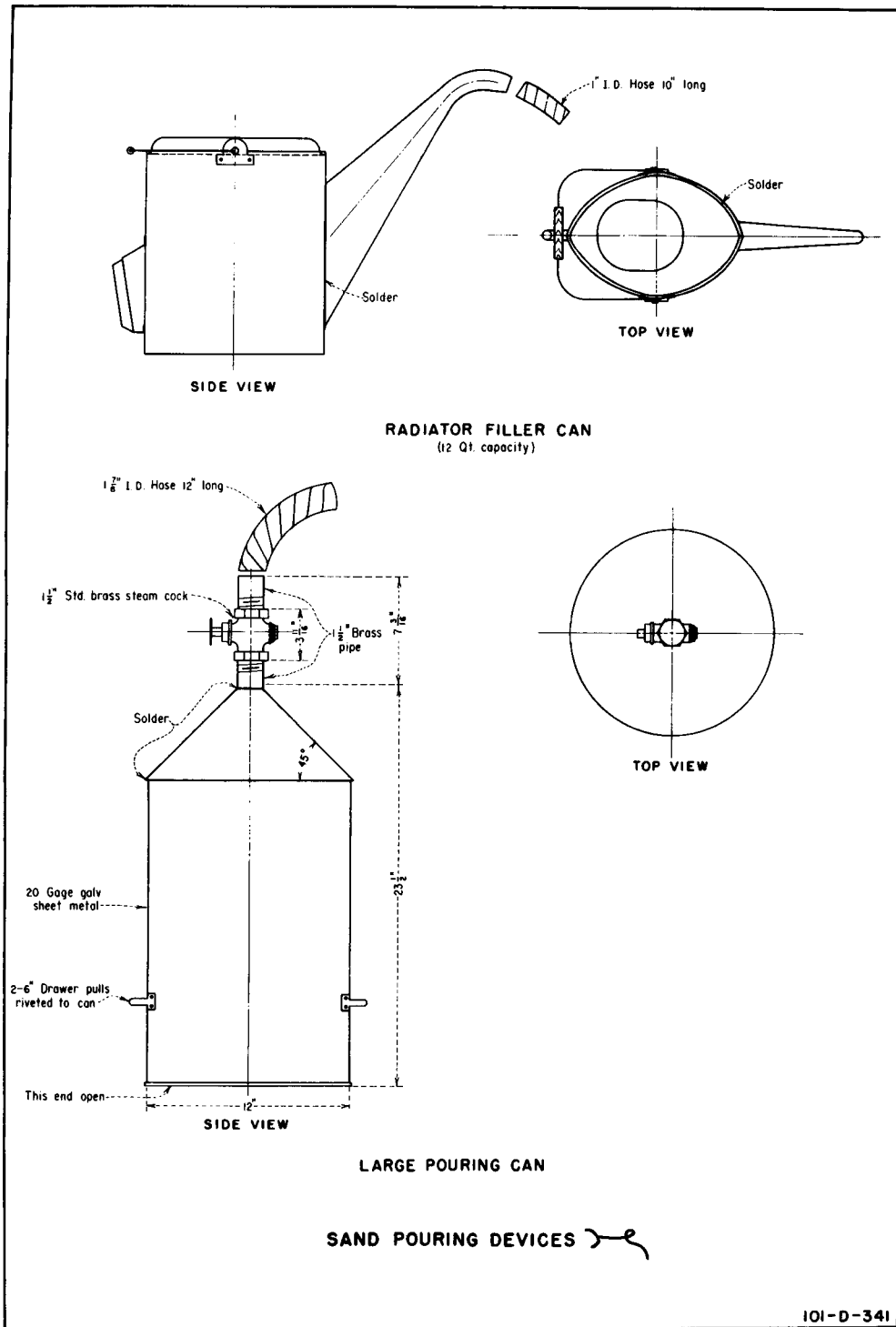

FIG. 2 Typical Sand Pouring Devices

each time. A valve that is only partially open can significantly alter the flow characteristics of the device. Each individual pouring device has unique characteristics which may cause the sand to flow from it differently. The final calibration values are affected by changes in these flow characteristics. Consequently, calibration values are not interchangeable, even for devices which may appear to be identical.

7.2.8 Do not allow pouring devices to run out of sand during the pouring operation. The size of the stream of poured sand

from the pouring device should be constant. If the reservoir capacity of the pouring device is too small to fill the test pit with one pour, use two or more pours to fill the test pit. Stop the stream of sand when the reservoir is about three-fourths empty and before the size of the stream diminishes. Refill the reservoir and resume pouring.

7.2.9 Pouring devices permit a varied sand drop distance that must be carefully controlled if consistent results are to be achieved. A distance of 2 in. (50 mm) from the end of the spout

to the surface being poured is recommended. Variations in the drop distance can significantly affect results. The drop distance is directly affected by the operator's ability to control the pouring device and by the operator's judgment of the drop distance while doing so. This involves stooping while holding a pouring device with an initial mass of 50 lbm (20 kg) or more that is constantly changing in mass as the sand flows into the test pit. Calibration values are not interchangeable from device to device and are not necessarily interchangeable from operator to operator. Individual operators must demonstrate that they can duplicate the calibration values for a device before they may use them, preferably within 1 % of the average value for another operator. Otherwise, separate calibrations for the various operators are required.

8. Calibration and Standardization

8.1 Calibrate the sand pouring equipment and sand in accordance with Annex A1.

9. Test Method A, Procedure—In-Place Density and Unit Weight of Total Material

9.1 Use Test Method A to determine a total unit weight (see 1.4).

9.2 Determine the recommended sample volume and select the appropriate template for the anticipated material gradation in accordance with Annex A2. Assemble the remainder of the required equipment.

9.3 Determine the mass of each combination of empty container, lid, and container liner (if used) that will contain the excavated material. Number the containers and mark as to use. Write the mass on the container or prepare a separate list.

9.4 Prepare the quantity of calibrated sand to be used.

9.4.1 Two sets of calibrated sand are necessary. Determining the volume of the test pit requires two separate sand pours to (1) measure the mass of sand used to fill the space between the soil surface and the top of the template, and (2) measure the mass of sand used to fill the test pit up to the top of the template. The difference between the two gives the mass of sand in the test pit.

9.4.2 Estimate the mass of calibrated sand and the number of containers required to fill the space between the soil surface and the top of the template. Calculate the estimated mass by multiplying the template volume by the density of the calibrated sand. Number the containers to be used and mark as to use, for example, "template correction." Fill the containers with sand. Determine and record on a separate list the mass of the containers and sand.

9.4.3 From the anticipated volume of the test pit, estimate the mass of calibrated sand required to fill the test pit. Increase this amount by about 25 % to ensure that a sufficient sand supply is available at the site, and then add to it the mass of sand calculated in 9.4.2. Calculate the estimated mass to be used for the test pit by multiplying the anticipated volume of the test pit by the density of the calibrated sand. Determine the number of containers required, number them, and mark as to use, for example, "test pit." Fill the containers with sand. Determine and record on a separate list the mass of the containers and sand.

9.5 Select a representative area for the test, avoiding loca-

tions where removal of large particles would undermine the template.

9.6 Prepare the surface of the area to be tested.

9.6.1 Remove all loose material from an area large enough on which to place the template. Prepare the exposed surface so that it is a firm, level plane.

9.6.2 Personnel should not step on the area selected for testing. Provide a working platform when testing materials which may flow or deform.

9.7 Place and seat the template on the prepared surface.

9.7.1 Use a hammer to firmly seat the template to avoid movement of the template while the test is performed. The use of nails, weights, or other means may be necessary to maintain the position.

9.7.2 Remove any material loosened while placing and seating the template, taking care to avoid leaving any void space under the template. If necessary, fill voids under the template with plastic soil, modeling clay, or other suitable material, provided that this material is not subsequently excavated as part of the material removed from the test pit.

9.8 Determine the mass of sand used to fill the space between the soil surface and the top of the template.

9.8.1 Irregularities of the soil surface within the template must be taken into account. To do this, determine the mass of sand required to fill the space between the soil surface and the top of the template.

9.8.2 It is recommended that a cloth with a hole slightly larger than the template center hole be placed over the template to facilitate locating and collecting any excess sand, or loose material, or both.

9.8.3 Place a liner (approximately ½-mil thick) over the template and shape it by hand to conform to the irregular soil surface and the template. The liner should extend approximately 1 ft (0.3 m) outside the template. The liner should not be stretched too taut or contain excessive folds or wrinkles (see Fig. 3).

9.8.4 Pour the calibrated sand onto the liner inside the template using a sand pouring device (see Fig. 4). Slightly overfill the template (see 7.2.7-7.2.9). Return any sand remaining in the pouring device to the original container.

9.8.5 Carefully level the calibrated sand by screeding with the steel straightedge across the top edges of the template. Return all screeded excess sand to the original container. Take care to avoid the loss of any excess sand.

9.8.6 Remove the calibrated sand in the template and, if the

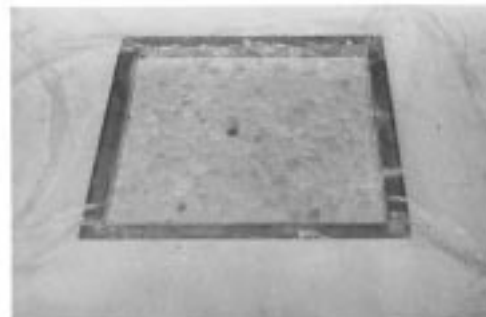

FIG. 3 Plastic Liner Placed Over the Template



FIG. 4 Sand Being Poured Into the Template

sand is to be reclaimed, place it in a specially marked container. Remove the liner.

9.9 Excavate the test pit.

9.9.1 Using handtools (chisel, knife, bar, etc.), excavate the center portion of the test pit.

9.9.1.1 Do not permit any movement of heavy equipment in the area of the test pit as deformation of the soil within the test pit may occur.

9.9.2 Place all material removed from the test pit in the container(s) (see Fig. 5), being careful to avoid losing any material (see 9.8.2).

9.9.3 Avoid moisture loss by keeping the container covered while material is not being placed in it. Use a sealable plastic bag inside the container to hold the material.

9.9.4 Carefully trim the sides of the excavation so that the dimensions of the test pit at the soil-template contact are as close as possible to that of the template hole. Avoid disturbing the template or the material beneath or outside the template.

9.9.5 Continue the excavation to the required depth, carefully removing any material that has been compacted or loosened in the process.

9.9.5.1 If during excavation of material from within the test pit, a particle(s) is found that is about 1½ times, or more, larger than the maximum particle size used to establish the dimensions and minimum volume of the test pit (see Annex A2), set the particle(s) aside and mark appropriately. Determine the mass and volume of the particle(s) and then subtract them from the mass and volume of the material removed from the test pit. Consider the larger particle(s) as “oversize” and follow the procedure outlined in Section 10, except that the “total” unit



FIG. 5 Excavation of the Test Pit

weight, which would include the larger particle(s), need not be calculated. The “control fraction” values determined then become the values for the total material from the test pit. If enough of these particles are found so that their mass is determined to be about 5 % or more of the mass of the excavated material, repeat the test with a larger test pit in accordance with the guidelines in Annex A2.

9.9.6 The sides of the pit should slope inward slightly. Materials that do not exhibit much cohesion may require a more conical-shaped test hole.

9.9.7 The profile of the finished pit must be such that poured sand will completely fill the excavation. The sides of the test pit should be as smooth as possible and free of pockets or overhangs or anything that might interfere with the free flow of the sand.

9.9.8 Clean the bottom of the test pit of all loosened material.

9.10 Determine the volume of the test pit.

NOTE 3—A liner may be required to prevent migration of the calibrated sand into the natural voids of the material mass. The liner, approximately ½-mil thick, should be large enough to extend approximately 1 ft (0.3 m) outside of the template after having been carefully placed and shaped to the soil surface within the pit. Allowances must be made for slack. The liner should not be stretched too taut nor contain excessive folds or wrinkles. Inspect the liner for punctures before use.

9.10.1 Pour the calibrated sand using the sand pouring device. Use the same pouring technique as used in the calibration procedure described in Annex A1. Slightly overfill the template. Return any sand remaining in the pouring device to the original container.

9.10.1.1 While the sand is being poured, avoid any vibrations in the test area.

9.10.2 Carefully level the calibrated sand by screeding with the steel straightedge across the top edges of the template. Return all screeded excess sand to the original container. Take care to avoid the loss of any excess sand.

9.10.3 If the calibrated sand is to be reclaimed, remove the used sand and place it into a specially marked container. Remove the liner and template.

9.11 Determine the dry unit weight.

9.11.1 Determine the mass of calibrated sand in the template (sand used to fill the space between the soil surface and the top of the template) as follows:

9.11.1.1 Calculate and record the total mass of the sand and containers prepared in 9.4.2. Record the container numbers.

9.11.1.2 Determine and record the total mass of the empty containers plus the sand residue (sand not used) and containers.

9.11.1.3 Calculate the mass of sand in the template and record.

9.11.2 Determine the mass of calibrated sand in the test pit and template (sand used to fill the test pit to the top of the template) as follows:

9.11.2.1 Calculate and record the total mass of the sand and containers prepared in 9.4.3. Record the container numbers.

9.11.2.2 Determine the total mass of the empty containers plus the sand residue and containers and record.

9.11.2.3 Calculate the mass of sand in the test pit and template (mass of sand used) and record.

9.11.3 Calculate the mass of the calibrated sand used to fill

the test pit and record.

9.11.4 Record the density of the calibrated sand (determined in the calibration procedure described in Annex A1).

9.11.5 Calculate the volume of the test pit and record.

9.11.6 Determine the total mass of the excavated material and containers.

9.11.7 Calculate and record the total mass of the containers used to hold the excavated material. Record the container numbers.

9.11.8 Calculate the mass of the excavated material and record.

9.11.9 Calculate the wet density of the excavated material.

9.11.10 If the excavated material contains oversize particles (normally larger than the No. 4 (4.75-mm) sieve for cohesive materials and 3-in. (75-mm) sieve for cohesionless materials), separate the material using the appropriate size sieve. If the material contains about 3 % (wet basis) or more oversize particles, Test Method B should be used.

9.11.11 If 2 % or less oversize particles are present, obtain a moisture content specimen representative of the excavated material and determine the moisture content in accordance with Test Method D 2216 or C 566 and record.

NOTE 4—For rapid moisture content determination of materials containing less than 15 % fines (minus No. 200), use a suitable source of heat such as an electric or gas hotplate. If a source of heat other than the controlled temperature oven is used, stir the test specimen to accelerate drying and avoid localized overheating. The material may be considered dry when further heating causes, or would cause, less than 0.1 % additional loss of mass.

9.11.12 If required or desired, calculate and record the dry density and dry unit weight of the material.

10. Test Method B, Procedure—In-Place Density and Unit Weight of Control Fraction

10.1 This test method is used when the material being tested contains oversize particles and the percent compaction or percent relative density of the control fraction are to be determined (see 1.4).

10.2 Obtain the in-place wet density of total material by following the procedure for Test Method A, as stated in 9.1-9.11.9.

10.3 To obtain the wet density of the control fraction, determine the mass and volume of the oversize particles and subtract them from the total mass and total volume to get the mass and volume of the control fraction. Then calculate the density of the control fraction from the mass and volume of the control fraction.

10.3.1 Normally, the wet density of the control fraction is determined and the dry density calculated using the moisture content of the control fraction.

10.3.2 In addition, the moisture content of the oversize particles, the moisture content of the total material, and the percentage of oversize particles may be determined.

10.4 After obtaining the wet mass of total material removed from the test pit, separate the material into the control fraction and the oversize particles using the designated sieve. Do this rapidly to minimize loss of moisture. If the test is for construction control, place the control fraction in an airtight container for further tests.

10.5 Wash the oversize particles and reduce the free water on the surface of the particles by blotting, draining, or a similar method.

10.6 Determine the wet mass of the oversize particles plus a container of predetermined mass, and record.

10.7 Calculate the wet mass of the oversize particles and record.

10.8 Calculate the wet mass of the control fraction and record.

10.9 Determine the volume of the oversize particles by one of the following procedures:

10.9.1 Determine and record the mass of all oversize particles suspended in water using the procedures and principles of Test Method C 127, disregarding the oven drying and 24-h soaking period. Calculate and record the volume of the oversize particles.

10.9.2 Calculate the volume of the oversize particles using a known bulk specific gravity value. If previous tests for bulk specific gravity of similar oversize particles from a particular source have been performed and the value is relatively constant, a bulk specific gravity may be assumed. The bulk specific gravity value used must correspond to the moisture condition of the oversize particles when their mass is determined. As used in this test method, determine the bulk specific gravity on the oversize particles in the moisture condition as stated in 10.5-10.7. If an oven dry or saturated surface dry (SSD) bulk specific gravity is used, then also determine the mass of the oversize particles for this test method on oven dry or SSD material, respectively.

10.10 Calculate the volume of the control fraction and record.

10.11 Calculate the wet density of the control fraction.

10.12 Determine the moisture content of the control fraction in accordance with Test Method D 2216 or C 566 (see Note 4) and record.

10.13 Calculate the dry density and dry unit weight of the control fraction and record.

10.14 If desired, determine and record the moisture content of all oversize particles in accordance with Test Method D 2216 or C 566 (see Note 4). If previous tests for moisture content of the oversize particles from a particular source have been performed and the value is relatively constant, a moisture content may be assumed.

10.15 If desired, determine the percentage of oversize particles as follows:

10.15.1 Calculate the dry mass of the control fraction and record.

10.15.2 Calculate the dry mass of the oversize particles and record.

10.15.3 Calculate the dry mass of the total sample and record.

10.15.4 Calculate the percentage of oversize particles and record.

10.16 Calculate the moisture content of the total material.

10.17 If desired, calculate the dry density and dry unit weight of the total material and record.

11. Test Method A, Calculation

11.1 Calculate the mass of the sand contained in the template as follows:

$$m_6 = m_2 - m_4 \quad (1)$$

where:

- m_6 = mass of sand in template, lbm (kg),
- m_2 = mass of template sand and container(s) (before test), lbm (kg), and
- m_4 = mass of template sand residue and container(s) (after test), lbm (kg).

11.2 Calculate the mass of the sand used to fill the test pit and template as follows:

$$m_5 = m_1 - m_3 \quad (2)$$

where:

- m_5 = mass of sand used, lbm (kg),
- m_1 = mass of sand and container(s) (before test), lbm (kg), and
- m_3 = mass of sand residue and container(s) (after test), lbm (kg).

11.3 Calculate the mass of the sand used to fill the test pit as follows:

$$m_7 = m_5 - m_6 \quad (3)$$

where:

- m_7 = mass of sand in test pit, lbm (kg),
- m_5 = mass of sand used, lbm (kg), and
- m_6 = mass of sand in template, lbm (kg).

11.4 Calculate the volume of the test pit as follows: (inch-pound)

$$V_T = \frac{m_7}{\rho_s} \quad (4)$$

(SI)

$$V_T = \frac{m_7}{\rho_s} \times \frac{1}{10^3} \quad (5)$$

where:

- V_T = volume of test pit, $\text{ft}^3(\text{m}^3)$,
- m_7 = mass of sand in test pit, lbm (kg), and
- ρ_s = density of calibrated sand, $\text{lbm}/\text{ft}^3 (\text{Mg}/\text{m}^3)$.

11.5 Calculate the mass of the wet material removed from test pit as follows:

$$m_{10} = m_8 - m_9 \quad (6)$$

where:

- m_{10} = mass of wet material removed from test pit, lbm (kg),
- m_8 = mass of wet material removed from test pit plus mass of container(s), lbm (kg), and
- m_9 = mass of container(s) for m_8 , lbm (kg).

11.6 Calculate the wet density of the material removed from test pit as follows: (inch-pound)

$$\rho_{wet} = \frac{m_{10}}{V_T} \quad (7)$$

(SI)

$$\rho_{wet} = \frac{m_{10}}{V_T} \times \frac{1}{10^3} \quad (8)$$

where:

- ρ_{wet} = wet density of material excavated from test pit, $\text{lbm}/\text{ft}^3 (\text{Mg}/\text{m}^3)$,
- m_{10} = mass of wet material removed from test pit, lbm (kg), and
- V_T = volume of test pit, $\text{ft}^3 (\text{m}^3)$.

11.7 Calculate the dry density of the material removed from test pit as follows:

$$\rho_d = \frac{\rho_{wet}}{1 + \left(\frac{w}{100}\right)} \quad (9)$$

where:

- ρ_d = dry density of material from test pit, $\text{lbm}/\text{ft}^3 (\text{Mg}/\text{m}^3)$,
- ρ_{wet} = wet density of material excavated from test pit, $\text{lbm}/\text{ft}^3 (\text{Mg}/\text{m}^3)$, and
- w = moisture content of material excavated from test pit, %.

11.8 Calculate the dry unit weight of the material removed from test pit as follows: (inch-pound)

$$\gamma_d = \rho_d \times \frac{1 \text{ lbf}}{1 \text{ lbm}} \quad (10)$$

where:

- γ_d = dry unit weight of material excavated from test pit, $\text{lb}/\text{ft}^3 (\text{kN}/\text{m}^3)$, and
- ρ_d = dry density of material from test pit, $\text{lbm}/\text{ft}^3 (\text{Mg}/\text{m}^3)$.

Assume that in the inch-pound system 1 lbm = 1 lbf. (SI)

$$\gamma_d = \rho_d \times 9.807 \quad (11)$$

where:

9.807 = the constant to convert Mg to kN.

11.9 If required, convert dry unit weight in inch-pound units to SI units as follows:

$$\text{unit weight, kN}/\text{m}^3 = \text{unit weight, lbf}/\text{ft}^3 \times 0.1571 \quad (12)$$

where:

0.1571 = the constant to convert pounds-force per cubic feet to kilonewton per cubic metre.

12. Test Method B, Calculation

12.1 Calculate the wet mass of the oversize particles as follows:

$$m_{13} = m_{11} - m_{12} \quad (13)$$

where:

- m_{13} = wet mass of oversize particles, lbm (kg),
- m_{11} = wet mass of oversize particles and container, lbm (kg), and
- m_{12} = mass of container, lbm (kg).

12.2 Calculate the wet mass of the control fraction as follows:

$$m_{18} = m_{10} - m_{13} \quad (14)$$

where:

m_{18} = wet mass of control fraction, lbm (kg),
 m_{10} = mass of wet material removed from test pit, lbm (kg), and
 m_{13} = wet mass of oversize particles, lbm (kg).

12.3 Calculate the volume of the oversize particles based on the mass in air and mass in water method as follows: (inch-pound)

$$V_{os} = \frac{m_{13} - m_{14}}{62.4 \text{ lbm/ft}^3} \quad (15)$$

(SI)

$$V_{os} = \frac{m_{13} - m_{14}}{1 \text{ g/cm}^3} \times \frac{1}{10^3} \quad (16)$$

where:

62.4 lbm/ft^3 = density of water,
 1 g/cm^3 = density of water,
 $\frac{1}{10^3}$ = constant to convert g/cm^3 to kg/m^3 ,
 $\frac{10^3}{m_{13}}$ = wet mass of oversize particles, lbm (kg), and
 m_{14} = mass of oversize particles suspended in water, lbm (kg).

12.4 Calculate the volume of the oversize particles based on a known bulk specific gravity as follows: (inch-pound)

$$V_{os} = \frac{m_{13}}{G_m \times (62.4)} \quad (17)$$

(SI)

$$V_{os} = \frac{m_{13}}{G_m \times (1 \text{ g/cm}^3)} \times \frac{1}{10^3} \quad (18)$$

where:

V_{os} = volume of oversize particles, ft^3 (m^3),
 m_{13} = wet mass of oversize particles, lbm (kg), and
 G_m = bulk specific gravity of oversize particles.

12.5 Calculate the volume of the control fraction as follows:

$$V_c = V_T - V_{os} \quad (19)$$

where:

V_c = volume of control fraction, ft^3 (m^3),
 V_T = volume of test pit, ft^3 (m^3), and
 V_{os} = volume of oversize particles, ft^3 (m^3).

12.6 Calculate the wet density of the control fraction as follows: (inch-pound)

$$\rho_{wet}(c) = \frac{m_{18}}{V_c} \quad (20)$$

(SI)

$$\rho_{wet}(c) = \frac{m_{18}}{V_c} \times \frac{1}{10^3} \quad (21)$$

where:

$\rho_{wet}(c)$ = wet density of control fraction, lbm/ft^3 (Mg/m^3),
 m_{18} = wet mass of control fraction, lbm (kg), and
 V_c = volume of control fraction, ft^3 (m^3).

12.7 Calculate the dry density of the control fraction as follows:

$$\rho_d(c) = \frac{\rho_{wet}(c)}{1 + \left(\frac{w_f}{100}\right)} \quad (22)$$

where:

$\rho_d(c)$ = dry density of control fraction, lbm/ft^3 (Mg/m^3),
 $\rho_{wet}(c)$ = wet density of control fraction, lbm/ft^3 (Mg/m^3), and
 w_f = moisture content of control fraction, %.

12.8 Calculate the dry unit weight of the control fraction as follows: (inch-pound)

$$\gamma_d(c) = \rho_d(c) \times \frac{1 \text{ lbf}}{1 \text{ lbm}} \quad (23)$$

Assume that in the inch-pound system $1 \text{ lbm} = 1 \text{ lbf}$. (SI)

$$\gamma_d(c) = \rho_d(c) \times 9.807 \quad (24)$$

where:

9.807 = constant to convert Mg to kN,
 $\gamma_d(c)$ = dry unit weight of control fraction, lbf/ft^3 (kN/m^3), and
 $\rho_d(c)$ = dry density of control fraction, lbm/ft^3 (Mg/m^3).

12.9 If required, convert dry unit weight in inch-pound units, to SI units, using Eq 12.

12.10 Calculate the dry mass of the control fraction as follows:

$$m_{19} = \frac{m_{18}}{1 + \left(\frac{w_f}{100}\right)} \quad (25)$$

where:

m_{19} = dry mass of control fraction, lbm (kg),
 m_{18} = wet mass of control fraction, lbm (kg), and
 w_f = moisture content of control fraction, %.

12.11 Calculate the dry mass of the oversize particles using one of the following equations as appropriate:

$$m_{17} = m_{15} - m_{16} \quad (26)$$

$$m_{17} = \frac{m_{13}}{1 + \left(\frac{w_{os}}{100}\right)} \quad (27)$$

where:

m_{17} = dry mass of oversize particles, lbm (kg),
 m_{15} = dry mass of oversize particles and container, lbm (kg),
 m_{16} = mass of container, lbm (kg),
 m_{13} = wet mass of oversize particles, lbm (kg), and
 w_{os} = moisture content of oversize particles, %.

12.12 Calculate the dry mass of the total sample as follows:

$$m_{20} = m_{19} + m_{17} \quad (28)$$

where:

m_{20} = dry mass of total sample (control fraction plus oversize), lbm (kg),
 m_{19} = dry mass of control fraction, lbm (kg), and
 m_{17} = dry mass of oversize particles, lbm (kg).

12.13 Calculate the percent oversize particles as follows:

$$p = \frac{m_{17}}{m_{20}} \times 100 \quad (29)$$

where:

- p = percent oversize,
- m_{17} = dry mass of oversize particles, lbm (kg), and
- m_{20} = dry mass of total sample (control fraction plus oversize), lbm (kg).

12.14 Calculate the moisture content of the total material as follows:

$$w = \frac{m_{10} - m_{20}}{m_{20}} \times 100 \quad (30)$$

where:

- w = moisture content of material excavated from test pit, %,
- m_{10} = mass of wet material removed from test pit, lbm (kg), and
- m_{20} = dry mass of total sample (control fraction plus oversize particles), lbm (kg).

12.15 Calculate the dry density and dry unit weight of the total material by using Eq 9 or Eq 10 and 11).

12.16 If required, convert dry unit weight in inch-pound units, to SI units, using Eq 12.

13. Report

- 13.1 Report the following information, as appropriate:
 - 13.1.1 Test location.
 - 13.1.2 Test location elevation.
 - 13.1.3 Test hole volume.
 - 13.1.4 In-place wet density, total or control fraction, or both.
 - 13.1.5 In-place dry density, total or control fraction, or both.

13.1.6 In-place dry unit weight, total or control fraction, or both.

13.1.7 In-place moisture content(s), total or control fraction, and test method used.

13.1.8 Test apparatus description.

13.1.9 Description of calibration procedures.

13.1.10 Density of calibrated sand.

13.1.11 Comments on test, as applicable.

13.1.12 Visual description of material.

13.1.13 If determined or assumed, bulk specific gravity and test method used.

13.1.14 If required, percentage of oversize particles.

14. Precision and Bias

14.1 *Precision*—Test data on precision is not presented due to the nature of the soil and rock materials being tested by these test methods. It is not feasible at this time to have ten or more agencies participate in an in situ testing program at a given site. Also, it is not feasible to produce multiple test locations having uniform properties. Any variation observed in the data is just as likely to be due to specimen variation as operator or laboratory testing variation.

14.1.1 Subcommittee D 18.08 is seeking any data from users of these test methods that might be used to make a limited statement on precision.

14.2 *Bias*—There is not accepted reference value for these test methods, therefore, bias cannot be determined.

15. Keywords

15.1 acceptance test; degree of compaction; density tests; field test; In-place density; pit test; quality control; sand replacement method

ANNEXES

(Mandatory Information)

A1. CALIBRATING SAND POURING EQUIPMENT AND SAND

A1.1 Scope

A1.1.1 This annex describes the procedure for calibrating sand pouring equipment and sand.

A1.1.2 The calibration determines an average density of poured sand for use in calculating the volume of a test pit excavated to determine in-place unit weight of soil and rock.

A1.2 Summary of Test Method

A1.2.1 Using a specific pouring device, sand is poured into a calibration mold of similar size and shape of a field test pit to determine the density of the sand as poured under specific conditions.

A1.3 Significance and Use

A1.3.1 This calibration procedure is performed to obtain the value of density of the sand using a specific pouring device for use in measuring the volume of a field unit weight test pit.

A1.3.2 This procedure should be performed:

A1.3.2.1 When a new supply of sand is processed into the storage bin.

A1.3.2.2 At intervals not exceeding 14 days when several unit weight tests are required on a daily basis.

A1.3.2.3 If tests are made at infrequent intervals, the sand must be calibrated before a test or series of tests is begun.

A1.3.2.4 For any change in equipment, personnel, or size or shape of the field test pit, (see 7.2.7-7.2.9).

A1.3.2.5 After any significant changes in atmospheric humidity, or change in moisture of the sand. The sand should be as dry as possible.

NOTE A1.1—Most sands have a tendency to absorb moisture from the atmosphere. A very small amount of absorbed moisture can make a substantial change in bulk density. In areas of high humidity or where the humidity changes often, the bulk density may need to be determined more often than the 14-day maximum interval indicated. The need for more frequent checks can be determined by comparing the results of different bulk-density tests on the same sand made in the area and conditions of use over a period of time.

A1.3.2.6 If tests are routinely made using reclaimed sand, calibrate when the cumulative mass of sand removed from the storage container equals the capacity of the container. A record of the mass of sand removed should be kept at a convenient location on or near the container.

A1.4 Apparatus

A1.4.1 *Metal Straightedge*—About 2 in. (50 mm) high, at least 1/8 in. (3 mm) thick, and with a length 1.5 times the side length of the calibration mold.

A1.4.2 *Mold*—A mold or container is required that is similar to the size and shape of the test pit excavated in the material. The volume of the mold shall be determined in accordance with the principles described in Test Method D 4253.

A1.4.3 *Miscellaneous Equipment*—Buckets to mix and reclaim sand, pans, thick paper, and miscellaneous brushes and scoops for reclaiming sand.

A1.5 Technical Hazards

A1.5.1 Consistent sand flow (see 7.2.7-7.2.9).

A1.5.2 *Vibration of Poured Sand*:

A1.5.2.1 Any vibration or jarring of poured sand, whether the pouring process is complete or not, causes densification of the sand and results in erroneous test results. To achieve consistent results, the sand must be free to flow without any outside agitation.

A1.5.2.2 Striking off material above the top of the calibration mold must be done consistently with as little vibration as possible.

A1.5.2.3 Place calibration molds on rigid, vibration free surfaces while performing the calibration.

A1.5.3 *Reclaimed Sand*:

A1.5.3.1 As a general rule, reclaiming sand is no longer desirable or economically feasible.

A1.5.3.2 If sand is reclaimed, after each recovery it must be screened over a sieve that would pass its original maximum particle size to eliminate clay balls or other foreign matter. Discard the sand after three usages.

A1.6 Conditioning

A1.6.1 Store the sand in covered bins or containers to maintain a uniformly dry condition. A 55-gal barrel with a valve near the bottom makes an excellent storage container. An internal heat source, such as a heat tape, may be necessary in storage containers in areas that experience significant changes in atmospheric moisture.

A1.6.2 When a new supply of sand is introduced into the storage bin and before each calibration, thoroughly mix the sand and blend. Calibration records must document new shipments of sand and dates that new sand is introduced into the current storage bin.

A1.7 Procedure

A1.7.1 Determine and record the mass of the mold.

A1.7.2 Place the calibration mold on a rigid surface.

A1.7.3 Using the pouring device, pour the sand into the calibration mold, slightly overfilling. Use a circular motion to keep the sand surface relatively level. Keep the end of the spout about 2 in. (50 mm) above the sand surface while pouring. A constant sand drop distance and the avoidance of any vibration of the measure are critical to the achievement of consistent results (see A1.5.2).

A1.7.3.1 If the reservoir capacity is too small to fill the calibration mold with one pour, use two or more pours to fill the mold. See 7.2.8 for the procedure to follow when more than one pour is necessary.

A1.7.4 Strike off the excess sand even with the top of the calibration mold using the metal straightedge (see A1.5.2.2).

A1.7.5 Determine the mass of the sand and calibration mold and record.

A1.7.6 Calculate the mass of sand in the calibration mold and record.

A1.7.7 Calculate the density of the sand and record.

A1.7.8 Repeat the procedure in A1.7.1-A1.7.7 as a second trial.

A1.7.9 Determine the uniformity of the two values obtained by dividing either value by the other. If the value of the ratio is between 0.990 and 1.010, inclusive, average the two values and record the average density. If the value of the ratio falls outside the limits, go to A1.7.10.

A1.7.9.1 Compare the average density with previously determined values to see if it is consistent and reasonable. If it is not, go to A1.7.10.

A1.7.10 Check to see that all equipment is performing correctly, that all calibrations are correct, and that the procedures and techniques used are correct. If no problems are discovered, then repeat procedure. If the values are still inconsistent, go to A1.7.11.

A1.7.11 Thoroughly mix all the sand being represented by this calibration and repeat the procedure. If the values are still inconsistent, discard all the sand and repeat the procedure using fresh sand from the original supply.

A1.8 Calculation

A1.8.1 Calculate the density of the sand as follows: (inch-pound)

$$\rho_s = \frac{m}{V} \quad (\text{A1.1})$$

(SI)

$$\rho_s = \frac{m}{V} \times \frac{1}{10^3} \quad (\text{A1.2})$$

where:

ρ_s = density of sand, lbf/ft³ (Mg/m³),

m = mass of sand in calibration mold, lbf (kg), and

V = volume of calibration mold, ft³ (m³).

A2. GUIDELINES FOR TEST HOLE OR TEST DIMENSIONS AND SELECTION OF EQUIPMENT

A2.1 This annex covers guidelines for selecting the excavation dimensions and the type of equipment to use based on the maximum particle size present in the material (or control fraction) being tested. These guidelines apply to both these test methods and to the companion Test Method D 5030 for using water replacement to determine the volume of an excavated test pit. The guidelines are given in Table A2.1 and Table A2.2. (Metric equivalents for these two tables are provided in Table A2.3.) The typical types of test pit excavation shapes are shown in Fig. A2.1.

A2.2 These guidelines are based on providing a representative sample of the material being tested and on practical working conditions. For a discussion of the shape and dimensions of the test pits and for the minimum volumes for the excavation, see Appendix X1 in Test Method D 5030 .

A2.3 The guidelines shown in Table A2.1 apply to test pit Types A and B (see Fig. A2.1). These test pits generally are for non-free draining materials or for cohesionless materials whose gradation and particle angularity will allow near-vertical side walls to be excavated.

A2.4 The guidelines shown in Table A2.2 apply to test pit Type C (see Fig. A2.1). This type of test pit can be excavated when Type A or B cannot. For this case, the slope of the side walls will be much flatter, approximately the angle of repose of the material.

A2.5 These guidelines are only applicable when the limitations stated in 1.5 and 1.6 for unstable or soft materials are followed.

TABLE A2.1 Test Apparatus and Minimum Excavation Volume^A

NOTE 1—More than 18-in. maximum particle size should be determined on a case-by-case basis.

Maximum Particle Size in. ^B	Minimum Required Volume, ft ³	Suggested Apparatus and Template Opening	Required Minimum Depth, in. ^C
3	1.0	24-in. square frame	18
5	2	30-in. square frame	12
8	8	4-ft diameter ring	24
12	27	6-ft diameter ring	24
18	90	9-ft diameter ring	36

^ATest Pit Types A and B (see Fig. A2.1).

^BMaximum particle size present in total material or the maximum particle size of control fraction if the total in-place unit weight is not of concern.

^CThis depth is necessary to obtain the minimum required volume of material when using the suggested apparatus and template opening.

TABLE A2.2 Test Apparatus and Minimum Excavation Volume^A

NOTE 1—More than 8-in. maximum particle size should be determined on a case-by-case basis.

Maximum Particle Size, in. ^B	Minimum Required Volume, ft ³	Suggested Apparatus and Template Opening	Required Minimum Depth, in. ^C	Approximate Diameter of Excavated Hole, in.
3	1.0	33-in. square frame	10	30
5	2	40-in. square frame	12	35
8	8	62-in. diameter ring	18	54

^ATest Pit TypeC (see Fig. A2.1).

^BMaximum particle size present in total material or the maximum particle size of control fraction if the total in-place unit weight is not of concern.

^CThis depth is necessary to obtain the minimum required volume of material when using the suggested apparatus and template opening.

TABLE A2.3 Metric Equivalentents for Table A2.1 and Table A2.2

Inches	Millimetres
3	75
5	125
8	200
10	250
12	300
18	450
24	600
30	750
33	825
35	875
36	900
40	1000
54	1350
62	1550
Feet	Metres
4	1.2
6	1.8
9	2.7
Cubic Feet	Cubic Metres
1.0	0.03
2	0.06
8	0.23
27	0.76
90	2.55

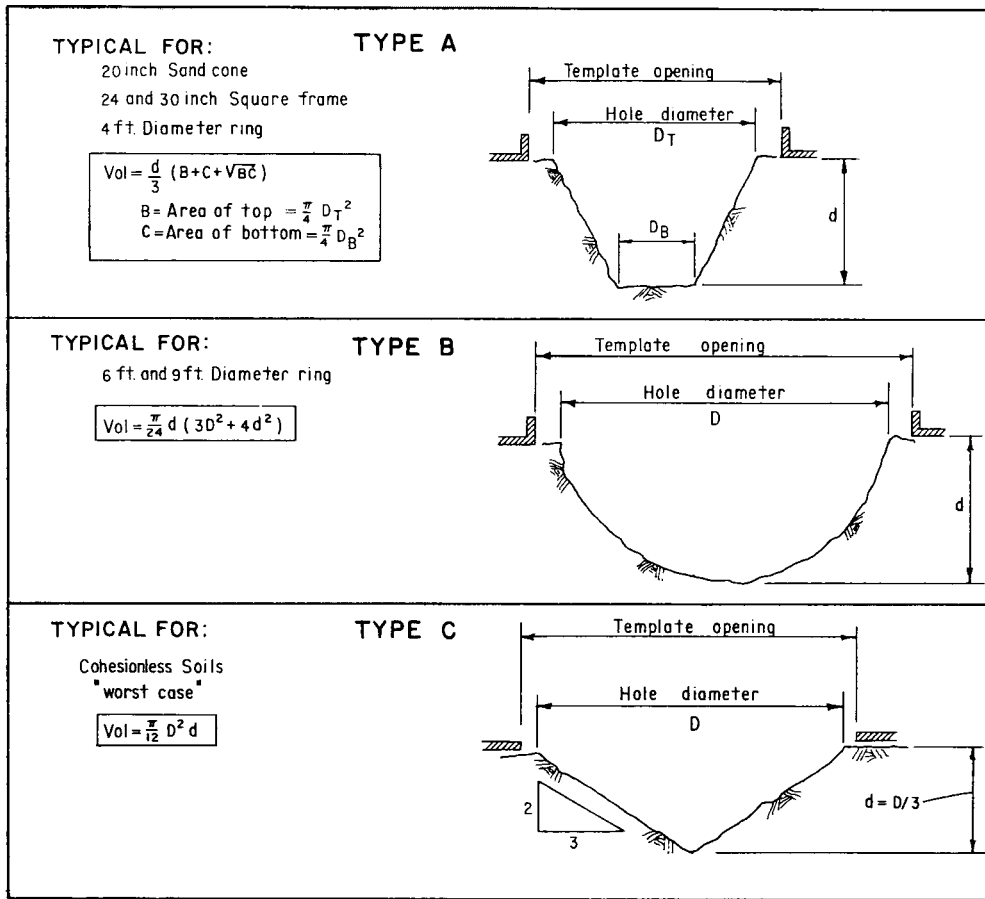

FIG. A2.1 Test Pit Configurations

SUMMARY OF CHANGES

In accordance with Committee D-18 policy, this section identifies the location of changes to this standard since the last edition 89 (1994)^{e1} that may impact the use of this standard.

- | | |
|--|---|
| <p>(1) Added Practice D 3740 to Section 2.
 (2) Added new note in 5.2 on the use of Practice D 3470.
 (3) Renumbered existing notes.</p> | <p>(4) Revised Precision and Bias Statement to conform to Committee D-18 Policy.
 (5) Added Summary of Changes.</p> |
|--|---|

The American Society for Testing and Materials takes no position respecting the validity of any patent rights asserted in connection with any item mentioned in this standard. Users of this standard are expressly advised that determination of the validity of any such patent rights, and the risk of infringement of such rights, are entirely their own responsibility.

This standard is subject to revision at any time by the responsible technical committee and must be reviewed every five years and if not revised, either reapproved or withdrawn. Your comments are invited either for revision of this standard or for additional standards and should be addressed to ASTM Headquarters. Your comments will receive careful consideration at a meeting of the responsible technical committee, which you may attend. If you feel that your comments have not received a fair hearing you should make your views known to the ASTM Committee on Standards, at the address shown below.

This standard is copyrighted by ASTM, 100 Barr Harbor Drive, PO Box C700, West Conshohocken, PA 19428-2959, United States. Individual reprints (single or multiple copies) of this standard may be obtained by contacting ASTM at the above address or at 610-832-9585 (phone), 610-832-9555 (fax), or service@astm.org (e-mail); or through the ASTM website (www.astm.org).